

Orange peel grab with 4 tines or 5 tines for the handling of bulky scrap with excavators from 16t/35200lbs to 22t/48400lbs operating weight.

- ▷ 4 tines version available with **pointed tines**.
- ▷ With **5 tines** available in **4 different tine profiles**:
 - F: fully closing tines
 - H: half closing tines
 - W: wide style of pointed tines
 - T: pointed tines
- ▷ **Hydraulic cylinders** are fitted with **replaceable piston rod protection**.
- ▷ **Oil distribution and hydraulic hoses are protected** in the centre section.
- ▷ Shell bearings with **high resistant steel bushings and hardened, ground pins**.
- ▷ **Shell tips made of 500HB cutting edge material, exchangeable individually** as wear parts.
- ▷ Closing force 17kN/3740lbf at an operating pressure of 35 MPa/5070psi, varies depending on width.
- ▷ **Non-return valve** is optionally available.



Orange Peel Grab P22V

Type	Width E (closed) (mm/in)	Opening A (mm/in)	Height C max. (mm/in)	Height C min. (mm/in)	Volume (liter/c.y.)	Number of tines (pcs.)	Weight (kg/lbs)	Load capacity (kg/lbs)
P22V-450-4-T	1370 / 53.9	1910 / 75.2	1545 / 60.8	1240 / 48.8	450 / 0.6	4	810 / 1782	7000 / 15400
P22V-450-5-F	1370 / 53.9	1910 / 75.2	1545 / 60.8	1240 / 48.8	450 / 0.6	5	1145 / 2519	7000 / 15400
P22V-450-5-H	1370 / 53.9	1910 / 75.2	1545 / 60.8	1240 / 48.8	450 / 0.6	5	1035 / 2277	7000 / 15400
P22V-450-5-W	1370 / 53.9	1910 / 75.2	1545 / 60.8	1240 / 48.8	450 / 0.6	5	970 / 2134	7000 / 15400
P22V-450-5-T	1370 / 53.9	1910 / 75.2	1545 / 60.8	1240 / 48.8	450 / 0.6	5	950 / 2090	7000 / 15400

Package consists of: orange peel grab, **KINSHOFER** rotator, head plate

KINSHOFER Rotator

Continuous rotation and two oil passages. Overload protection is ensured by pressure relief valves.

Type	Upper connection (width x pin-Ø) (mm/in)	Torque (Nm/ft.lbs)	Bending moment max. (Nm/ft.lbs)
KM 10 F275-60	125 x 60 / 4.9 x 2.4	2000 / 1475	14000 / 10325

Accessories

Type	Description
KM 501 13t-25t	upper suspension without pendulum damper
KM 511 13t-25t	upper suspension with pendulum damper
KSW10 cardanic	adapter for system L-Lock KMS10L/KHS10L incl. cardan link excl. pendulum damper - up to 19t/ 41800lbs.
KSW21/25 cardanic	adapter for system L-Lock KMS21/25L / KHS21/25L incl. cardan link excl. pendulum damper
	adapters for quick change systems from other manufacturers or different sizes on request

Requirements of carrier machine

Operating pressure (open/close):	max. 35 MPa (350 bar) / 5070psi
Pump capacity (open/close):	50 - max. 150 l/min / 13 - max. 40GPM
Operating pressure (rotate):	max. 32 MPa (320 bar) / 4640psi
Pump capacity (rotate):	20 - max. 50 l/min / 5 - max. 13GPM

Technical drawing

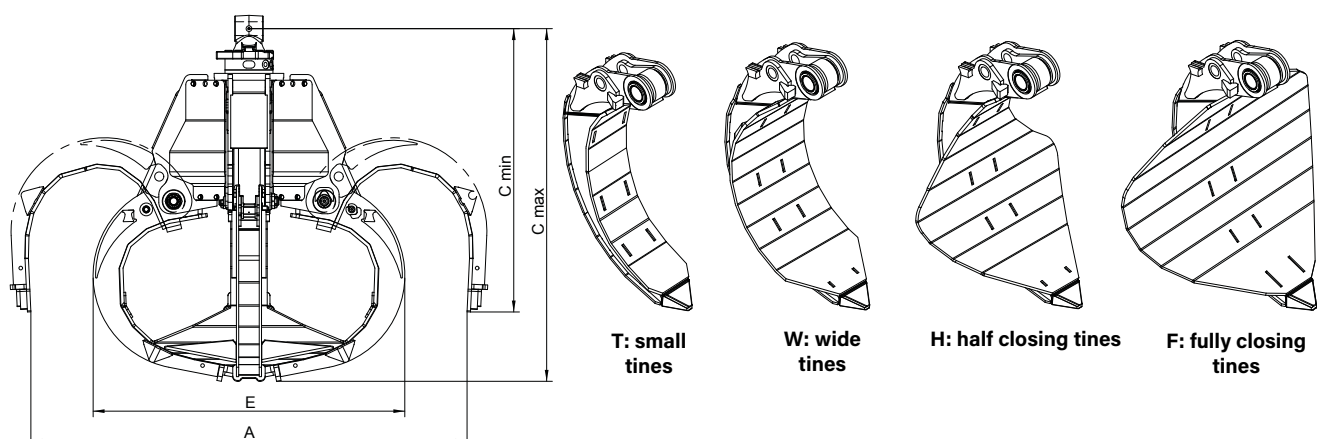

Orange peel grab with 3 tines and 600l/0.78c.y. or 3 or 4 tines and 800l/1.05c.y. volume for the handling of bulky scrap with excavators from 18t/39600lbs to 25t/55000lbs operating weight. Especially developed for heavy duty tasks.

- ▷ **Hydraulic cylinders** are fitted with **replaceable piston rod protection** and **are hydraulically cushioned**.
- ▷ **Greasing points are easily accessible**.
- ▷ **Reinforced tines** made of wear-resistant steel 400HB.
- ▷ **Weld-on tips** made of high resistant forged and tempered steel 500HB.
- ▷ **Accurate fittings** eliminate tine distortion, **solid end stops** (open & close).
- ▷ **Reinforced bolts**, large bearing surface for bolts, specially **coated solid steel bushings**.
- ▷ **Robust, fully integrated rotation** with sturdy slewing ring with internal hoses guarantees optimum force transmission and prevents hose break. The **integrated pressure relief valve** protects against overcharge.
- ▷ **Swivel and bevel sealed**. Rotary feedthrough and motor accessible directly.
- ▷ **Non-return valve** is optionally available.
- ▷ **High closing force** 38kN/8360lbf. at an operating pressure of 35MPa/5070psi, varies depending on width.



Orange Peel Grab P25VR HD

Type	Width E (closed) (mm/in)	Opening A (mm/in)	Height C max. (mm/in)	Volume (liter/c.y.)	Number of tines (pcs.)	Weight (kg/lbs)	Load capacity (kg/lbs)
P25VR HD-600-3-W*	1420 / 55.9	2200 / 86.6	1775 / 69.9	600 / 0.78	3	1650 / 3630	3000 / 6600
P25VR HD-800-3-W*	1560 / 61.4	2200 / 86.6	1775 / 69.9	800 / 1.05	3	1700 / 3740	3000 / 6600
P25VR HD-800-4-W*	1550 / 61	2250 / 88.6	1780 / 70.1	800 / 1.05	4	1980 / 4356	3000 / 6600

* prices w/o adapter

Package consists of: orange peel grab, integrated rotation with sturdy slewing ring, head plate, hose guard, bolt-on bottom plate with welded lifting eye

Accessories

Type	Description
KM 691 27t	adapter for specific solutions – up to 27t/59400lbs
KM 690 20t	adapter for rigid mounting – up to 20t/44000lbs
KM 690 27t	adapter for rigid mounting – up to 27t/59400lbs
OQ	bolt-on adapter for Oilquick OQ – 5t to 70t/11000lbs to 154000lbs
KSW10 rigid	bolt-on adapter for system L-Lock KMS10L/KHS10L – up to 19t/41800lbs
KSW21/25 rigid	bolt-on adapter for system L-Lock KMS21/25L / KHS21/25L – up to 40t/88000lbs
	adapters for quick change systems from other manufacturers or different sizes on request

Requirements of carrier machine

	P25VR HD-3-W	P25VR HD-4-W
Operating pressure (open/close):	max. 35 MPa (350 bar) / 5070psi	max. 35 MPa (350 bar) / 5070psi
Pump capacity (open/close):	120 - max. 200 l/min / 32 - max. 53GPM	120 - max. 200 l/min / 32 - max. 53GPM
Hydraulic connection (open/close):	G 3/4"	G 3/4"
Operating pressure (rotate):	14 MPa (140 bar) / 2030psi	14 MPa (140 bar) / 2030psi
Pump capacity (rotate):	max. 50 l/min / 13GPM	max. 50 l/min / 13GPM
Hydraulic connection (rotate):	G 1/2"	G 1/2"

Technical drawing

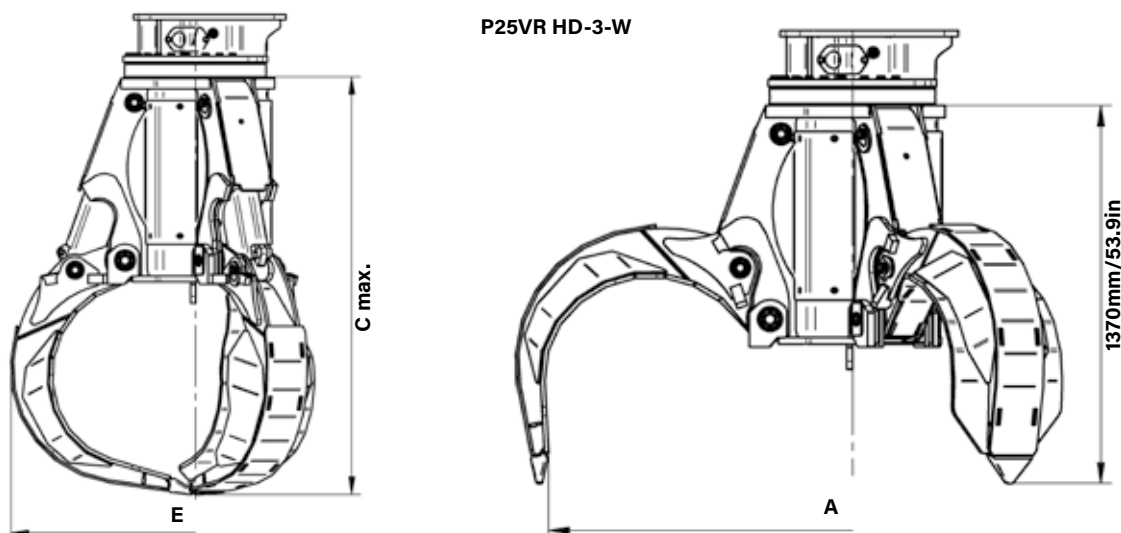

Orange peel grab with 4 or 5 tines and 600l/ 0.78c.y. or 800l/1.05c.y. volume for the handling of bulky scrap with excavators from 20t/44000lbs to 30t/66000lbs operating weight - for heavy duty tasks.

- ▷ Available in **two different volumes and diverse tine profiles**.
- ▷ Hydraulic cylinders are fitted with **replaceable piston rod protection** and are **hydraulically cushioned**.
- ▷ **Oil distribution and hydraulic hoses are protected** in the carrier.
- ▷ **Reinforced tines** made of wear-resistant steel 400HB.
- ▷ **Weld-on tips** made of high resistant forged and tempered steel 500HB.
- ▷ **Accurate fittings** eliminate tine distorsion, **solid end stops** (open & close).
- ▷ **Robust, fully integrated rotation** with sturdy slewing ring with internal hoses guarantees optimum force transmission and prevents hose break. The **integrated pressure relief valve** protects against overcharge.
- ▷ **Swivel and bevel sealed**. Rotary feedthrough and motor accessible directly.
- ▷ **Non-return valve** is optionally available.
- ▷ **High closing force** 27kN/5940lbf at an operating pressure of 35MPa/5070psi, varies depending on width.



Orange Peel Grab P30VHD

Type	Width E (closed) (mm/in)	Opening A (mm/in)	Height C max. (closed) (mm/in)	Volume (liter/c.y.)	Number of tines (pcs.)	Weight (kg/lbs)	Load capacity (kg/lbs)
P30VHD-600-4-F	1520 / 59.8	2130 / 83.9	1980 / 78.0	600 / 0.78	4	1600 / 3520	7000 / 15400
P30VHD-600-4-H	1520 / 59.8	2130 / 83.9	1980 / 78.0	600 / 0.78	4	1520 / 3344	7000 / 15400
P30VHD-600-4-W	1520 / 59.8	2130 / 83.9	1980 / 78.0	600 / 0.78	4	1385 / 3047	7000 / 15400
P30VHD-600-4-T	1520 / 59.8	2130 / 83.9	1980 / 78.0	600 / 0.78	4	1360 / 2992	7000 / 15400
P30VHD-600-5-F	1520 / 59.8	2130 / 83.9	1980 / 78.0	600 / 0.78	5	1770 / 3894	7000 / 15400
P30VHD-600-5-H	1520 / 59.8	2130 / 83.9	1980 / 78.0	600 / 0.78	5	1670 / 3674	7000 / 15400
P30VHD-600-5-W	1520 / 59.8	2130 / 83.9	1980 / 78.0	600 / 0.78	5	1595 / 3509	7000 / 15400
P30VHD-600-5-T	1520 / 59.8	2130 / 83.9	1980 / 78.0	600 / 0.78	5	1570 / 3454	7000 / 15400
P30VHD-800-5-F	1525 / 60.0	2290 / 90.2	2065 / 81.3	800 / 1.05	5	1750 / 3850	7000 / 15400
P30VHD-800-5-H	1525 / 60.0	2290 / 90.2	2065 / 81.3	800 / 1.05	5	1690 / 3718	7000 / 15400
P30VHD-800-5-W	1525 / 60.0	2290 / 90.2	2065 / 81.3	800 / 1.05	5	1560 / 3432	7000 / 15400
P30VHD-800-5-T	1525 / 60.0	2290 / 90.2	2065 / 81.3	800 / 1.05	5	1540 / 3388	7000 / 15400

Package consists of: orange peel grab, integrated rotation with sturdy slewing ring, head plate, hose guard, bolt-on bottom plate with welded lifting eye

Accessories

Type	Description
KM 501 RD50	upper suspension without pendulum damper
KSW21/25 cardanic	adapter for system L-Lock KMS21/25L / KHS21/25L incl. cardan link excl. pendulum damper
	adapters for quick change systems from other manufacturers or different sizes on request

Requirements of carrier machine

Operating pressure (open/close):	max. 35 MPa (350 bar) / 5070psi
Pump capacity (open/close):	120 - max. 200 l/min / 32 - max. 53GPM
Hydraulic connection (open/close):	1"
Operating pressure (rotate):	17 MPa (170 bar) / 2460psi
Pump capacity (rotate):	20 - max. 30 l/min / 5 - max. 8GPM
Hydraulic connection (rotate):	1/2"

Technical drawing

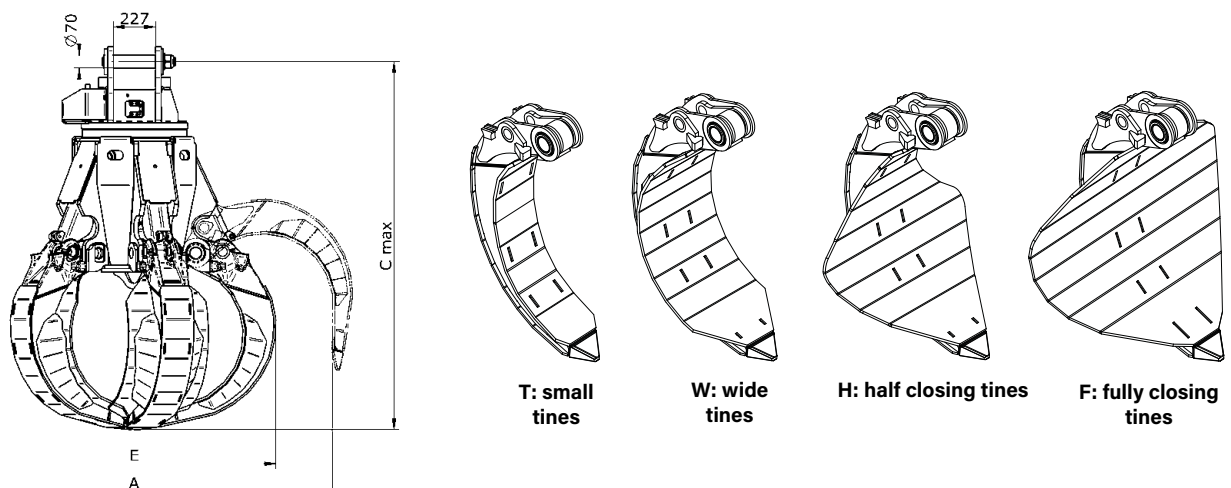

Orange peel grab with 4 or 5 tines and 600l/0.78c.y. or 800l/1.05c.y. volume for the handling of bulky scrap with excavators with up to 40t/88000lbs operating weight - for heavy duty tasks.



- ▷ Available in **two different volumes and diverse tine profiles.**
- ▷ Hydraulic cylinders are fitted with **replaceable piston rod protection** and are **hydraulically cushioned.**
- ▷ **Oil distribution and hydraulic hoses are protected** in the carrier.
- ▷ **Reinforced tines** made of wear-resistant steel 400HB.
- ▷ **Weld-on tips** made of high resistant forged and tempered steel 500HB.
- ▷ **Accurate fittings** eliminate tine distorsion, **solid end stops** (open & close).
- ▷ **Reinforced bolts**, large bearing surface for bolts, specially coated **solid steel bushings.**
- ▷ **Robust, fully integrated rotation** with sturdy slewing ring with internal hoses guarantees optimum force transmission and prevents hose break. The **integrated pressure relief valve** protects against overcharge.
- ▷ **Swivel and bevel sealed.** Rotary feedthrough and motor accessible directly.
- ▷ **Non-return valve** is optionally available.
- ▷ **High closing force** 38 kN/8360lbf at an operating pressure of 35MPa/5070psi, varies depending on width.

Orange Peel Grab P40VHD

Type	Width E (closed) (mm/in)	Opening A (mm/in)	Height C max. (closed) (mm/in)	Volume (liter/c.y.)	Number of tines (pcs.)	Weight (kg/lbs)	Load capacity (kg/lbs)
P40VHD-600-5-H	1430 / 56.3	2200 / 86.6	2170 / 85.4	600 / 0.78	5	1830 / 4026	10000 / 22000
P40VHD-600-5-W	1430 / 56.3	2200 / 86.6	2170 / 85.4	600 / 0.78	5	1780 / 3916	10000 / 22000
P40VHD-600-5-T	1430 / 56.3	2200 / 86.6	2170 / 85.4	600 / 0.78	5	1620 / 3674	10000 / 22000
P40VHD-800-4-W	1570 / 61.8	2200 / 86.6	2170 / 85.4	800 / 1.05	4	1670 / 3674	10000 / 22000
P40VHD-800-4-T	1570 / 61.8	2200 / 86.6	2170 / 85.4	800 / 1.05	4	1530 / 3366	10000 / 22000
P40VHD-800-5-F	1570 / 61.8	2200 / 86.6	2170 / 85.4	800 / 1.05	5	2035 / 4477	10000 / 22000
P40VHD-800-5-H	1570 / 61.8	2200 / 86.6	2170 / 85.4	800 / 1.05	5	1950 / 4290	10000 / 22000
P40VHD-800-5-W	1570 / 61.8	2200 / 86.6	2170 / 85.4	800 / 1.05	5	1940 / 4268	10000 / 22000
P40VHD-800-5-T	1570 / 61.8	2200 / 86.6	2170 / 85.4	800 / 1.05	5	1760 / 3872	10000 / 22000

Package consists of: orange peel grab, integrated rotation with sturdy slewing ring, head plate, hose guard, bolt-on bottom plate with welded lifting eye

Accessories

Type	Description
KM 501 RD50	upper suspension without pendulum damper
KSW21/25 cardanic	adapter for system L-Lock KMS21/25L / KHS21/25L incl. cardan link excl. pendulum damper
	adapters for quick change systems from other manufacturers or different sizes on request

Requirements of carrier machine

Operating pressure (open/close):	max. 35 MPa (350 bar) / 5070psi
Pump capacity (open/close):	120 - max. 200 l/min / 32 - max. 53GMP
Hydraulic connection (open/close):	1"
Operating pressure (rotate):	max. 17 MPa (170 bar) / 2460psi
Pump capacity (rotate):	20 - max. 30 l/min / 5 - max. 8GMP
Hydraulic connection (rotate):	1/2"

Technical drawing

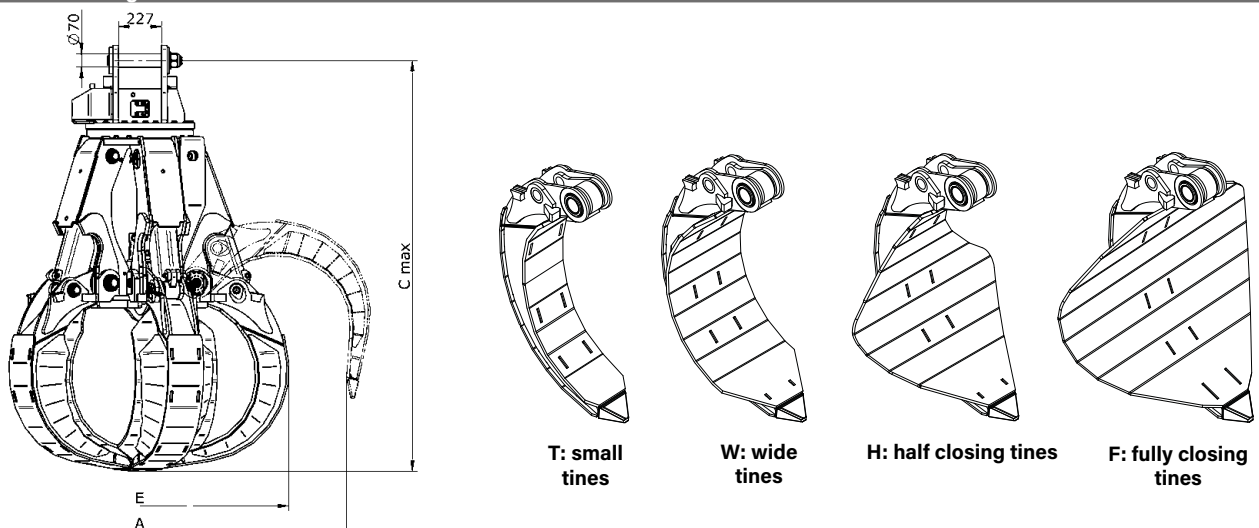

Orange peel grab with 3 tines for the handling of bulky scrap with excavators from 26t/57200lbs to 40t/88000lbs operating weight - for heavy duty tasks.

- ▷ Hydraulic cylinders are fitted with **replaceable piston rod protection** and are **hydraulically cushioned**.
- ▷ **Easy accessible greasing points**.
- ▷ **Reinforced tines** made of wear-resistant steel 400HB.
- ▷ **Weld-on tips** made of high resistant forged and tempered steel 500HB.
- ▷ **Accurate fittings** eliminate tine distortion, **solid end stops** (open & close).
- ▷ **Reinforced bolts**, large bearing surface for bolts, specially coated **solid steel bushings**.
- ▷ **Robust, fully integrated rotation** with sturdy slewing ring with internal hoses guarantees optimum force transmission and prevents hose break. The **integrated pressure relief valve** protects against overcharge.
- ▷ **Swivel and bevel sealed**. Rotary feedthrough and motor accessible directly.
- ▷ **Non-return valve** is optionally available.
- ▷ **High closing force** 38 kN/8360lbf. at an operating pressure of 35MPa/5070lbs., varies depending on width.



Orange Peel Grab P40VHD

Type	Width E (closed) (mm/in)	Opening A (mm/in)	Height C max. (closed) (mm/in)	Volume (liter/c.y.)	Number of tines (pcs.)	Weight (kg/lbs)	Load capacity (kg lbs)
P40VHD-600-3-W*	1420 / 55.9	2200 / 86.6	2170 / 85.4	600 / 0.78	3	1390 / 3058	6000 / 13200
P40VHD-800-3-W*	1585 / 62.4	2200 / 86.6	2170 / 85.4	800 / 1.05	3	1430 / 3146	6000 / 13200
P40VHD-1000-3-W	1630 / 64.2	2440 / 96.1	2300 / 90.6	1000 / 1.31	3	1585 / 3487	6000 / 13200
P40VHD-1250-3-W	1830 / 72.0	2660 / 104.7	2415 / 95.1	1250 / 1.64	3	1660 / 3652	6000 / 13200
P40VHD-1500-3-W	1860 / 73.2	2835 / 111.6	2510 / 98.8	1500 / 1.96	3	2045 / 4499	6000 / 13200

* prices w/o adapter

Package consists of: orange peel grab, integrated rotation with sturdy slewing ring, head plate, hose guard, bolt-on bottom plate with welded lifting eye

Accessories

Type	Description
KM 501 RD50	upper suspension without pendulum damper
KSW21/25 cardanic	adapter for system L-Lock KMS21/25L / KHS21/25L incl. cardan link excl. pendulum damper
	adapters for quick change systems from other manufacturers or different sizes on request

Requirements of carrier machine

Operating pressure (open/close):	max. 35 MPa (350 bar) / 5070psi
Pump capacity (open/close):	120 - max. 200 l/min / 32 - 53GPM
Hydraulic connection (open/close):	1"
Operating pressure (rotate):	max. 17 MPa (170 bar) / 2460psi
Pump capacity (rotate):	20 - max. 30 l/min / 5 - max. 8GPM
Hydraulic connection (rotate):	1/2"

Technical drawing

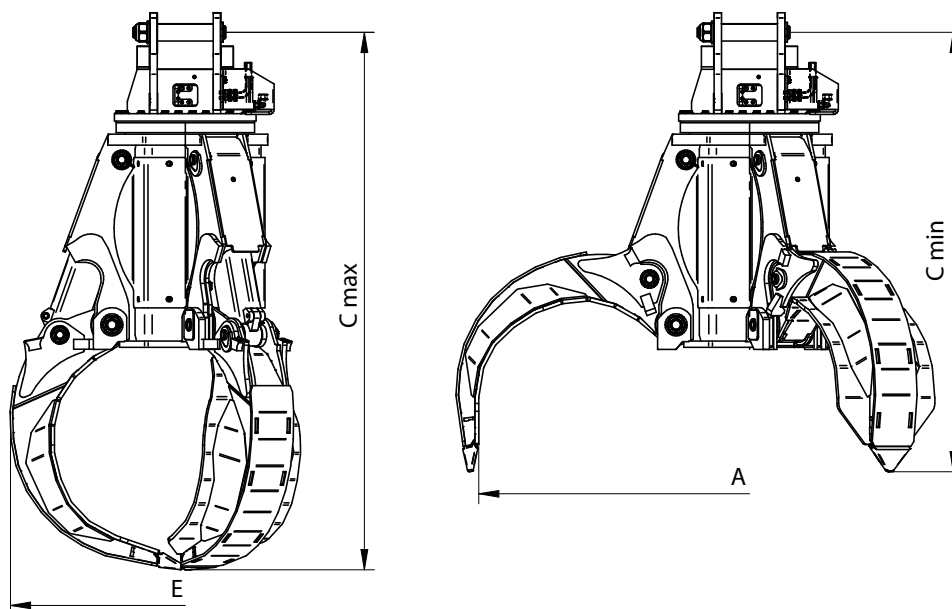

Orange peel grab with 4 or 5 tines and 1000l/1.31c.y. , 1250l/1.64c.y. or 1500l/1.96c.y. volume for the handling of bulky scrap with excavators from 36t/79200lbs to 50t/110000lbs operating weight - for heavy duty tasks.

- ▷ With 4 or 5 tines in different forms F, H, W, T.
- ▷ Hydraulic cylinders are fitted with **replaceable piston rod protection** and are **hydraulically cushioned**.
- ▷ **Oil distribution and hydraulic hoses are protected** in the carrier.
- ▷ **Reinforced tines** made of wear-resistant steel 400HB.
- ▷ **Weld-on tips** made of high resistant forged and tempered steel 500HB.
- ▷ **Accurate fittings** eliminate tine distorsion, **solid end stops** (open & close).
- ▷ **Reinforced bolts**, large bearing surface for bolts, specially coated **solid steel bushings**.
- ▷ **Robust, fully integrated rotation** with sturdy slewing ring with internal hoses guarantees optimum force transmission and prevents hose break. The **integrated pressure relief valve** protects against overcharge.



Orange Peel Grab P51VHD

Type	Width E (closed) (mm/in)	Opening A (mm/in)	Height C max. (closed) (mm/in)	Volume (liter/c.y.)	Number of tines (pcs.)	Weight (kg/lbs)	Load capacity (kg/lbs)
P51VHD-1000-4-W	1630 / 64.2	2440 / 96.1	2200 / 86.6	1000 / 1.31	4	1755 / 3861	10000 / 22000
P51VHD-1000-4-T	1630 / 64.2	2440 / 96.1	2200 / 86.6	1000 / 1.31	4	1715 / 3773	10000 / 22000
P51VHD-1000-5-F	1630 / 64.2	2440 / 96.1	2200 / 86.6	1000 / 1.31	5	2165 / 4763	10000 / 22000
P51VHD-1000-5-H	1630 / 64.2	2440 / 96.1	2200 / 86.6	1000 / 1.31	5	2110 / 4642	10000 / 22000
P51VHD-1000-5-W	1630 / 64.2	2440 / 96.1	2200 / 86.6	1000 / 1.31	5	2050 / 4510	10000 / 22000
P51VHD-1000-5-T	1630 / 64.2	2440 / 96.1	2200 / 86.6	1000 / 1.31	5	1830 / 4026	10000 / 22000
P51VHD-1250-5-H	1835 / 72.2	2665 / 104.9	2415 / 95.1	1250 / 1.64	5	2195 / 4829	10000 / 22000
P51VHD-1250-5-W	1835 / 72.2	2665 / 104.9	2415 / 95.1	1250 / 1.64	5	2185 / 4807	10000 / 22000
P51VHD-1500-4-H	1870 / 73.6	2840 / 111.8	2500 / 98.4	1500 / 1.96	4	2000 / 4400	10000 / 22000
P51VHD-1500-4-W	1870 / 73.6	2840 / 111.8	2500 / 98.4	1500 / 1.96	4	1830 / 4026	10000 / 22000
P51VHD-1500-5-F	1870 / 73.6	2840 / 111.8	2500 / 98.4	1500 / 1.96	5	2360 / 5192	10000 / 22000
P51VHD-1500-5-H	1870 / 73.6	2840 / 111.8	2500 / 98.4	1500 / 1.96	5	2305 / 5071	10000 / 22000
P51VHD-1500-5-W	1870 / 73.6	2840 / 111.8	2500 / 98.4	1500 / 1.96	5	2245 / 4939	10000 / 22000
P51VHD-1500-5-T	1870 / 73.6	2840 / 111.8	2500 / 98.4	1500 / 1.96	5	1995 / 4389	10000 / 22000

Package consists of: orange peel grab, integrated rotation with sturdy slewing ring, head plate, hose guard, non-return valve and bolt-on bottom plate with welded lifting eye

Accessories

Type	Description
KM 501 RD50	upper suspension without pendulum damper adapters for quick change systems from other manufacturers or different sizes on request

Requirements of carrier machine

Operating pressure (open/close):	max. 35 MPa (350 bar) / 5070psi
Pump capacity (open/close):	120 - max. 200 l/min/ 32.0 - max. 53.0GPM
Operating pressure (rotate):	max. 17 MPa (170 bar) / 2460psi
Pump capacity (rotate):	20 - max. 30 l/min/ 5.0 - max. 8.0GPM

Technical drawing

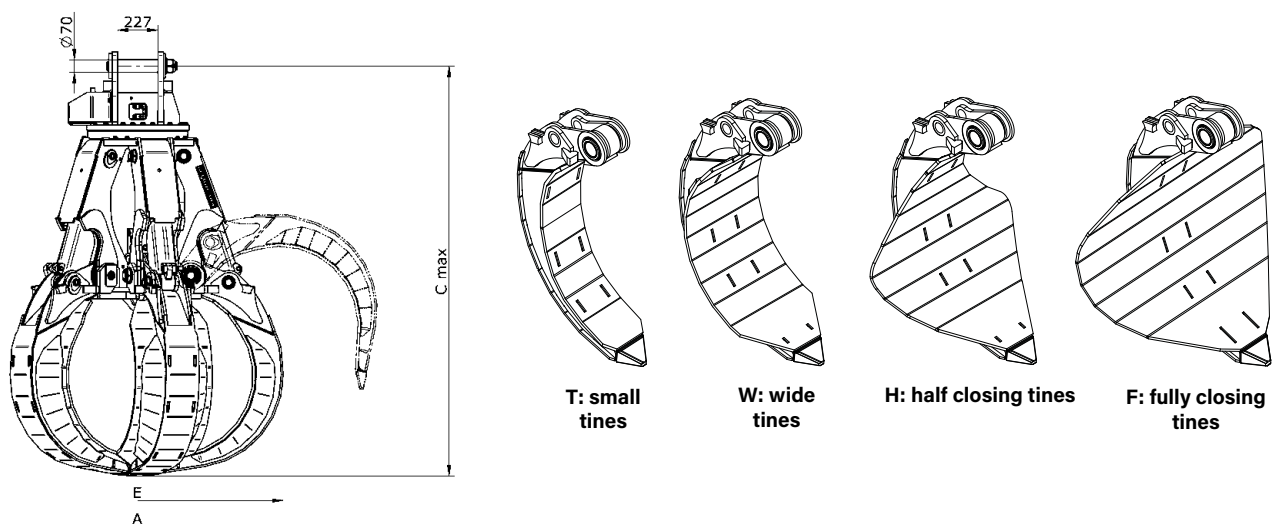

Orange peel grab with 4 or 5 tines and 1500l/1.96c.y., 2000l/2.62c.y. or 3000l/3.92c.y. volume for the handling of bulky scrap with excavators from 50t/110000lbs to 80t/176000lbs operating weight - for heavy duty tasks.

- ▷ With **3 different volumes and shell forms H, W and T.**
- ▷ Hydraulic cylinders are fitted with **replaceable piston rod protection** and are **hydraulically cushioned.**
- ▷ **Oil distribution and hydraulic hoses are protected** in the carrier.
- ▷ **Reinforced tines** made of wear-resistant steel 400HB.
- ▷ **Weld-on tips** made of high resistant forged and tempered steel 500HB.
- ▷ **Accurate fittings** eliminate tine distorsion, **solid end stops** (open & close).
- ▷ **Reinforced bolts**, large bearing surface for bolts, specially coated **solid steel bushings.**
- ▷ **Robust, fully integrated rotation** with sturdy slewing ring with internal hoses guarantees optimum force transmission and prevents hose break. The **integrated pressure relief valve** protects against overcharge.



Orange Peel Grab P80VHD Heavy Duty

Type	Width E (closed) (mm/in)	Opening A (mm/in)	Height C max. (closed) (mm/in)	Volume (liter/c.y.)	Number of tines (pcs.)	Weight (kg/lbs)	Load capacity (kg/lbs)
P80VHD-1500-4-T	2010 / 79.1	2770 / 109.1	2770 / 109.1	1500 / 1.96	4	2500 / 5500	10000 / 22000
P80VHD-2000-5-H	2070 / 81.5	3180 / 125.2	2970 / 116.9	2000 / 2.62	5	3200 / 7040	10000 / 22000
P80VHD-2000-5-W	2070 / 81.5	3180 / 125.2	2970 / 116.9	2000 / 2.62	5	3000 / 6600	10000 / 22000
P80VHD-2000-5-T	2070 / 81.5	3180 / 125.2	2970 / 116.9	2000 / 2.62	5	2780 / 6116	10000 / 22000
P80VHD-2500-5-H	2200 / 86.6	3360 / 132.3	3065 / 120.7	2500 / 3.27	5	3310 / 7282	10000 / 22000
P80VHD-2500-5-W	2200 / 86.6	3360 / 132.3	3065 / 120.7	2500 / 3.27	5	3110 / 6842	10000 / 22000
P80VHD-2500-5-T	2200 / 86.6	3360 / 132.3	3065 / 120.7	2500 / 3.27	5	2890 / 6358	10000 / 22000
P80VHD-3000-5-H	2325 / 91.5	3540 / 139.4	3155 / 124.2	3000 / 3.92	5	3420 / 7524	10000 / 22000
P80VHD-3000-5-W	2325 / 91.5	3540 / 139.4	3155 / 124.2	3000 / 3.92	5	3220 / 7084	10000 / 22000

Package consists of: orange peel grab, integrated rotation with sturdy slewing ring, head plate, hose guard, non-return valve and bolt-on bottom plate with welded lifting eye

Accessories

Type	Description
------	-------------

KM 501 RD120	upper suspension without pendulum damper adapters for quick change systems from other manufacturers or different sizes on request
--------------	--

Requirements of carrier machine

Operating pressure (open/close):	max. 35 MPa (350 bar) / 5070psi
Pump capacity (open/close):	max. 350 l/min / 92.5GPM
Operating pressure (rotate):	max. 20 MPa (200 bar) / 2900psi
Pump capacity (rotate):	20 - max. 60 l/min / 5.0 - max. 16.0GPM

Technical drawing

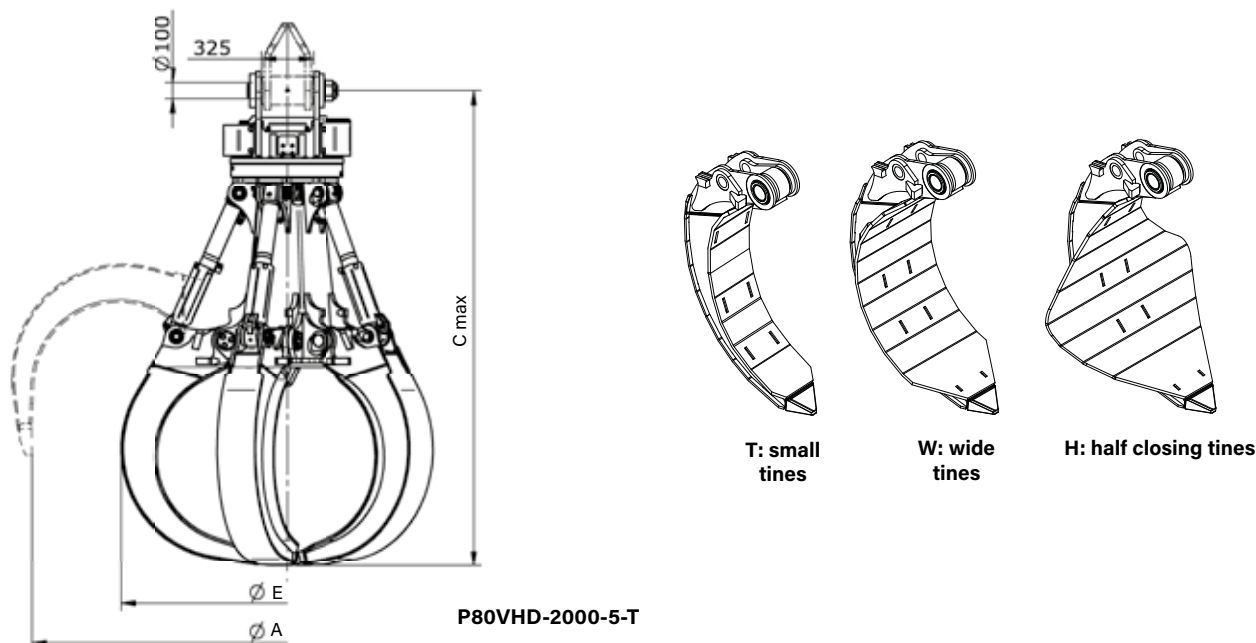

Orange peel grab with 5 tines and 2000 l or 3000 l/6.62c.y. or 3.92c.y. volume for the handling of bulky scrap with excavators from 80t/176000lbs to 120t/264000lbs operating weight - for heavy duty tasks.

- ▷ With **2 different volumes and 3 shell forms H, W and T.**
- ▷ Hydraulic cylinders are fitted with **replaceable piston rod protection** and are **hydraulically cushioned.**
- ▷ **Oil distribution and hydraulic hoses are protected** in the carrier.
- ▷ **Reinforced tines** made of wear-resistant steel 400HB.
- ▷ **Weld-on tips** made of high resistant forged and tempered steel 500HB.
- ▷ **Accurate fittings** eliminate tine distortion, **solid end stops** (open & close).
- ▷ **Reinforced bolts**, large bearing surface for bolts, specially coated **solid steel bushings.**
- ▷ **Robust, fully integrated rotation** with sturdy slewing ring with internal hoses guarantees optimum force transmission and prevents hose break. The **integrated pressure relief valve** protects against overcharge.



Orange Peel Grab P120VHD Heavy Duty

Type	Width E (closed) (mm/in)	Opening A (mm/in)	Height C max. (mm/in)	Volume (liter/c.y.)	Number of tines	Weight (kg/lbs)	Load capacity (kg/lbs)
P120VHD-2000-5-H	2280 / 89.8	3200 / 126.0	3180 / 125.2	2000 / 2.62	5	4570 / 10054	10000 / 22000
P120VHD-2000-5-W	2280 / 89.8	3200 / 126.0	3180 / 125.2	2000 / 2.62	5	4370 / 9614	10000 / 22000
P120VHD-2000-5-T	2280 / 89.8	3200 / 126.0	3180 / 125.2	2000 / 2.62	5	4220 / 9284	10000 / 22000
P120VHD-3000-5-H	2390 / 94.1	3910 / 153.9	3350 / 131.9	3000 / 3.92	5	4700 / 10340	10000 / 22000
P120VHD-3000-5-W	2390 / 94.1	3910 / 153.9	3350 / 131.9	3000 / 3.92	5	4500 / 9900	10000 / 22000
P120VHD-3000-5-T	2390 / 94.1	3910 / 153.9	3350 / 131.9	3000 / 3.92	5	4350 / 9570	10000 / 22000

Package consists of: orange peel grab, integrated rotation with sturdy slewing ring, head plate, hose guard and non-return valve

Accessories

Type	Description
KM 501 RD120	upper suspension without pendulum damper adapters for quick change systems from other manufacturers or different sizes on request

Requirements of carrier machine

Operating pressure (open/close):	max. 35 MPa (350 bar) / 5070psi
Pump capacity (open/close):	200 - 350 l/min / 53.0 - 92.5 GPM
Operating pressure (rotate):	14 - 25 MPa (140 - 250 bar) / 2030 - 3620GPM
Pump capacity (rotate):	20 - 50 l/min / 5.0 - 13.0 GPM

Technical drawings

