



## Compactors

IHC - Fixed  
IHC R - Rotating

 **INDECO**

A TOOL FOR EVERY JOB



# Application areas

		IHC	IHC R		
 <p><b>Earth Moving and Construction</b></p>	<b>Earth moving works</b>	<ul style="list-style-type: none"> <li>Trenching</li> <li>Ground excavation</li> <li>Floor leveling</li> <li>Soil compaction</li> <li>Trench compaction</li> <li>Loading soil or bulk material</li> </ul>	<input type="checkbox"/> <input type="checkbox"/> <input type="checkbox"/> <input type="checkbox"/> <input type="checkbox"/> <input type="checkbox"/>		
	<b>Foundation works</b>	<ul style="list-style-type: none"> <li>Building foundation excavation</li> <li>Ground leveling</li> </ul>	<input type="checkbox"/> <input type="checkbox"/>		
	<b>Building construction</b>	<ul style="list-style-type: none"> <li>Foundation pile driving</li> <li>Compaction around pillars</li> </ul>	<input type="checkbox"/> <input type="checkbox"/>		
	 <p><b>Infrastructures</b></p>	<b>Tunnelling</b>	<ul style="list-style-type: none"> <li>Tunnel excavation</li> <li>Roof, face &amp; rib scaling</li> </ul>	<input type="checkbox"/> <input type="checkbox"/>	
		<b>Underwater application</b>	<ul style="list-style-type: none"> <li>Dredging</li> <li>Dock deepening &amp; extension</li> <li>Canal deepening &amp; extension</li> <li>Loading soil or bulk material</li> <li>Handling rock or breakwaters</li> </ul>	<input type="checkbox"/> <input type="checkbox"/> <input type="checkbox"/> <input type="checkbox"/> <input type="checkbox"/>	
		<b>Trenching</b>	<ul style="list-style-type: none"> <li>Oil &amp; gas, water &amp; sewage (deep trenching)</li> <li>Trenching</li> <li>Trench soil compaction</li> </ul>	<input type="checkbox"/> <input type="checkbox"/> <input type="checkbox"/>	
		<b>Road construction</b>	<ul style="list-style-type: none"> <li>Pile driving and guard rail driving</li> <li>Asphalt repair</li> <li>Maintenance work (driveways, sidewalks and parking lots)</li> <li>Block paving</li> </ul>	<input type="checkbox"/> <input type="checkbox"/> <input type="checkbox"/> <input type="checkbox"/>	
		 <p><b>Agriculture and Forestry</b></p>	<b>Gardening &amp; Landscaping</b>	<ul style="list-style-type: none"> <li>Fencing</li> <li>Ground excavation</li> <li>Rock breaking</li> <li>Pit planting</li> <li>Stump splitting</li> <li>Golf course maintenance</li> <li>Root and stump grinding</li> <li>Hedgerow clearance and rejuvenation</li> <li>Grinding of logging residues</li> </ul>	<input type="checkbox"/> <input type="checkbox"/> <input type="checkbox"/> <input type="checkbox"/> <input type="checkbox"/> <input type="checkbox"/> <input type="checkbox"/> <input type="checkbox"/>
			<b>Forestry</b>	<ul style="list-style-type: none"> <li>Timber log handling</li> <li>Maintenance of green area, small trees and brush</li> <li>Creation and upkeep of woodland corridors and firebreaks</li> <li>Tree clearing</li> <li>Vegetation clearing</li> <li>Branch clearing</li> </ul>	<input type="checkbox"/> <input type="checkbox"/> <input type="checkbox"/> <input type="checkbox"/> <input type="checkbox"/> <input type="checkbox"/>

# Features of Indeco compactors

Indeco IHC compactors combine high compaction with fast turnaround times. They are a very efficient replacement both for traditional risky and tiring manual equipment and for self-propelled rollers, which are at great risk of rollover during slope applications.

Compaction is achieved by applying both the dynamic force of a hydraulically-driven vibration system and the static weight of the carrier boom to the thick steel baseplate of the compactor.

Of course, the dynamic forces have to be powerful enough to vibrate the steel baseplate. To enable this to happen, Indeco compactors (mounted straight onto the carrier boom) are hydraulically driven with an oil-bath bearing system, which gives a balanced design of compaction force and vibration speed, so as to achieve the depth penetration needed to reduce air voids and move more material faster.

Indeco's fixed or rotating IHC hydraulic compactors offer superior efficiency and versatility compared with other products on the market. Being fitted with the same mounting bracket as other Indeco hydraulic equipment makes it easy to switch from one tool to another at the jobsite. Using just the carrier's hydraulic circuit, they are ideal for compacting backfill for trenches, as well as embankments or other steep slope applications, around foundations or close to other obstacles.

Perfect for working on grainy, cohesive and semi-cohesive soils, optional adapters on the vibratory plate turn them into highly efficient pile-driving tools. Indeco's rotating compaction plate, the IHC R, makes it much easier to position the excavator at the right angle to the working surface, especially for jobs in narrow pipe trenches and confined areas, where the compaction plate needs to reach into difficult corners or skirt round manholes and other obstacles.

Robust, versatile and highly productive, IHC compactors have a number of special features created by the technology researchers at Indeco. The system uses oil-bath bearings **|1|**, ensuring maximum reliability, low maintenance costs and high performance, even on the toughest of jobs.

The rubber shock-absorber system **|2|** is designed to direct the whole force down into the material to be compacted, thus isolating vibrations from the carrier and the operator.

The thick chassis and baseplates **|3|** are made from extra-strength steel alloys which means no flexing or other buckling that could affect performance. The hydraulic system **|4|** balances force and speed to ensure that the eccentric weights can achieve depth penetration and reduce air voids.

The compactor has been specially designed **|5|** to work up close to trench walls, foundations, guard rails and other obstacles, along the whole width and length of the job.

The pressure- and flow-control valve **|6|** provides safer quicker installation, ensuring that incorrect set-ups cannot affect the long-term reliability of the compactor.

The hydraulic connections **|7|** are located in a practical and functional area in the rear of the compactor. They run parallel with the carrier hoses, which protects them from accidental breakage, especially in deep narrow pipe trenches.

The motor **|8|**, with its special high-pressure seals, can withstand backpressure without the need for a drain line.

Full 360° hydraulic rotation **|9|** optimizes the position of the vibratory plate under any working conditions, moving more material faster.

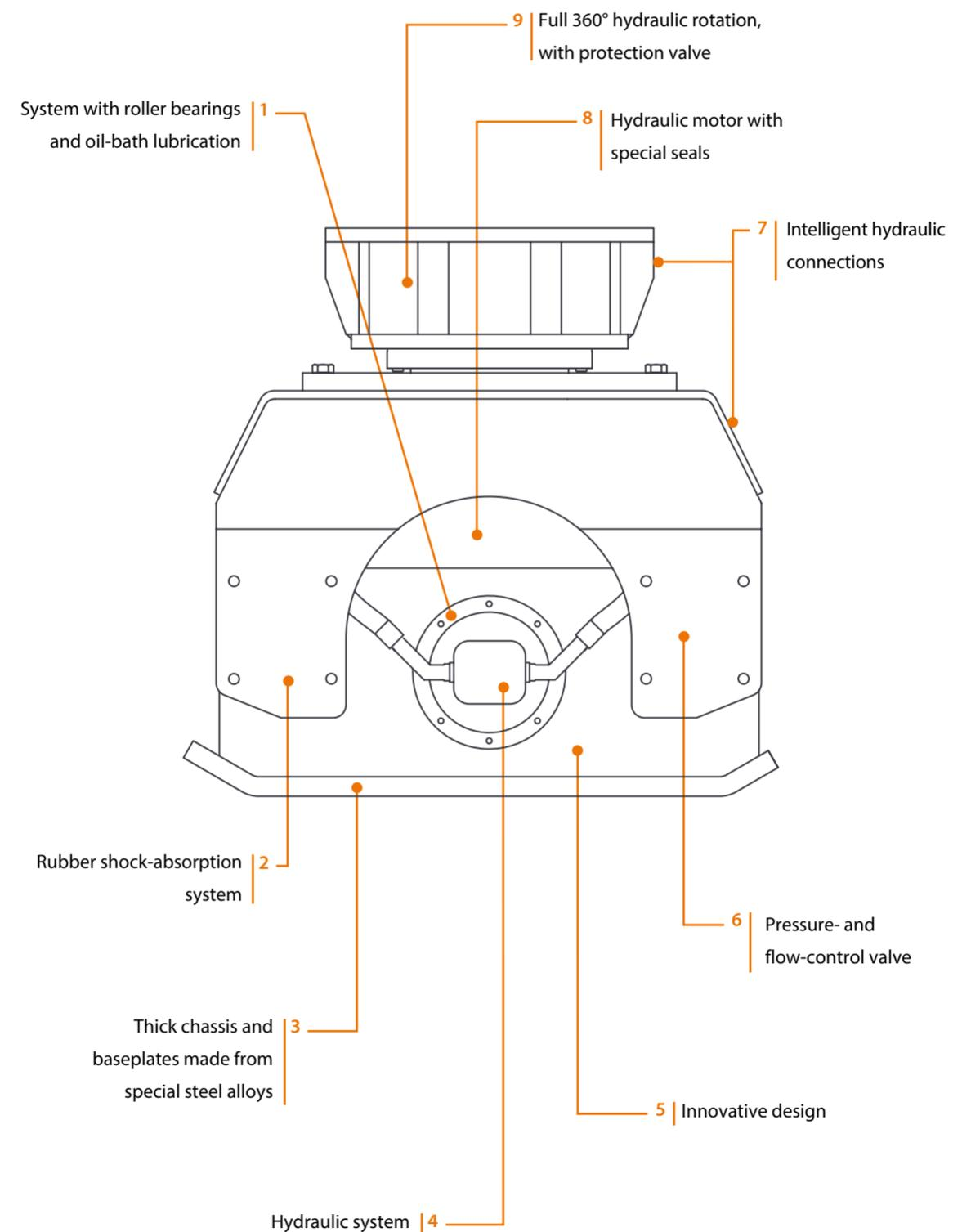



Technical Data	IHC 50	IHC 70	IHC 75
Type of carrier	1 3	1 3	1 3
Excavator weight	1,7 ÷ 8 tons	3,5 ÷ 13 tons	4 ÷ 14 tons
Equipment weight*	200 Kg	445 Kg	485 Kg
Height	56 cm	60 cm	60 cm
Baseplate size	30,5 x 76 cm	46 x 84 cm	64 x 87 cm
Centrifugal force	3000 Kgf 29,5 KN	4000 Kgf 39 KN	4000 Kgf 39 KN
Compacting force	1,7 Kg/cm <sup>2</sup> 16,7 N/cm <sup>2</sup>	1,1 Kg/cm <sup>2</sup> 10,8 N/cm <sup>2</sup>	1,1 Kg/cm <sup>2</sup> 10,8 N/cm <sup>2</sup>
Frequency	2000 - 3000 rpm 33 - 50 hz	2000 rpm 33 hz	2000 rpm 33 hz
Oil flow to motor	45 ÷ 70 l/min	75 l/min	75 l/min
Maximum working pressure adjusted to the excavator	240 bars	200 bars	200 bars
Maximum backpressure	7 bars	21 bars	21 bars
Compatibility of attachment plate with mounting bracket	HP 400	HP 900	HP 900

\*The operating weight of the equipment includes mounting bracket compatible with Indeco construction standards. Any differences in weight may be due to a different mounting bracket configuration.

#### Carrier key



Technical Data	IHC 150	IHC 250
Type of carrier	4 5	4 5
Excavator weight	8 ÷ 22 tons	15 ÷ 45 tons
Equipment weight*	970 Kg	1280 Kg
Height	79 cm	80 cm
Baseplate size	71 x 120 cm	90 x 122 cm
Centrifugal force	10000 Kgf 98 KN	17000 Kgf 167 KN
Compacting force	1,8 Kg/cm <sup>2</sup> 17,7 N/cm <sup>2</sup>	2,2 Kg/cm <sup>2</sup> 21,6 N/cm <sup>2</sup>
Frequency	2000 rpm 33 hz	1800 - 2200 rpm 30 - 37 hz
Oil flow to motor	120 l/min	190 ÷ 265 l/min
Maximum working pressure adjusted to the excavator	200 bars	170 bars
Maximum backpressure	21 bars	7 bars
Compatibility of attachment plate with mounting bracket	HP 1500 - HP 1800	HP 2000 - HP 2500 HP 3000 ÷ HP 4000

N.B. All illustrations and numerical data in this catalog are purely indicative and subject to change at our discretion and without notice. We therefore reserve the right to modify them with a view to improving and continuously developing our product.

#### Compatibility

Suggested uses on machines with an overall weight (in tons):





Technical Data	IHC R 50	IHC R 70	IHC R 75
Type of carrier	1 3	1 3 4	1 3 4
Excavator weight	3,5 ÷ 13 tons	6,5 ÷ 16 tons	7 ÷ 16 tons
Equipment weight*	425 Kg	630 Kg	670 Kg
Height	88 cm	93 cm	93 cm
Baseplate size	30,5 x 76 cm	46 x 84 cm	64 x 87 cm
Centrifugal force	3000 Kgf 29,5 KN	4000 Kgf 39 KN	4000 Kgf 39 KN
Compacting force	1,7 Kg/cm <sup>2</sup> 16,7 N/cm <sup>2</sup>	1,1 Kg/cm <sup>2</sup> 10,8 N/cm <sup>2</sup>	1,1 Kg/cm <sup>2</sup> 10,8 N/cm <sup>2</sup>
Frequency	2000 - 3000 rpm 33 - 50 hz	2000 rpm 33 hz	2000 rpm 33 hz
Oil flow to motor	45 ÷ 70 l/min	75 l/min	75 l/min
Maximum working pressure adjusted to the excavator	240 bars	200 bars	200 bars
Maximum backpressure	7 bars	21 bars	21 bars
Oil delivery for rotation	10 l/min	10 l/min	10 l/min
Pressure regulated for rotation	90 bars	90 bars	90 bars
Compatibility of attachment plate with mounting bracket	HP 900	HP 900	HP 900

\*The operating weight of the equipment includes mounting bracket compatible with Indeco construction standards. Any differences in weight may be due to a different mounting bracket configuration.

#### Carrier key



Technical Data	IHC R 150	IHC R 250
Type of carrier	4 5	4 5
Excavator weight	15 ÷ 25 tons	16 ÷ 45 tons
Equipment weight*	1185 Kg	1520 Kg
Height	108 cm	110 cm
Baseplate size	71 x 120 cm	90 x 122 cm
Centrifugal force	10000 Kgf 98 KN	17000 Kgf 167 KN
Compacting force	1,8 Kg/cm <sup>2</sup> 17,7 N/cm <sup>2</sup>	2,2 Kg/cm <sup>2</sup> 21,6 N/cm <sup>2</sup>
Frequency	2000 rpm 33 hz	1800 - 2200 rpm 30 - 37 hz
Oil flow to motor	120 l/min	190 ÷ 265 l/min
Maximum working pressure adjusted to the excavator	200 bars	170 bars
Maximum backpressure	21 bars	7 bars
Oil delivery for rotation	10 l/min	10 l/min
Pressure regulated for rotation	90 bars	90 bars
Compatibility of attachment plate with mounting bracket	HP 2000 - HP 2500	HP 2000 - HP 2500

N.B. All illustrations and numerical data in this catalog are purely indicative and subject to change at our discretion and without notice. We therefore reserve the right to modify them with a view to improving and continuously developing our product.

#### Compatibility

Suggested uses on machines with an overall weight (in tons):



# Performance curves

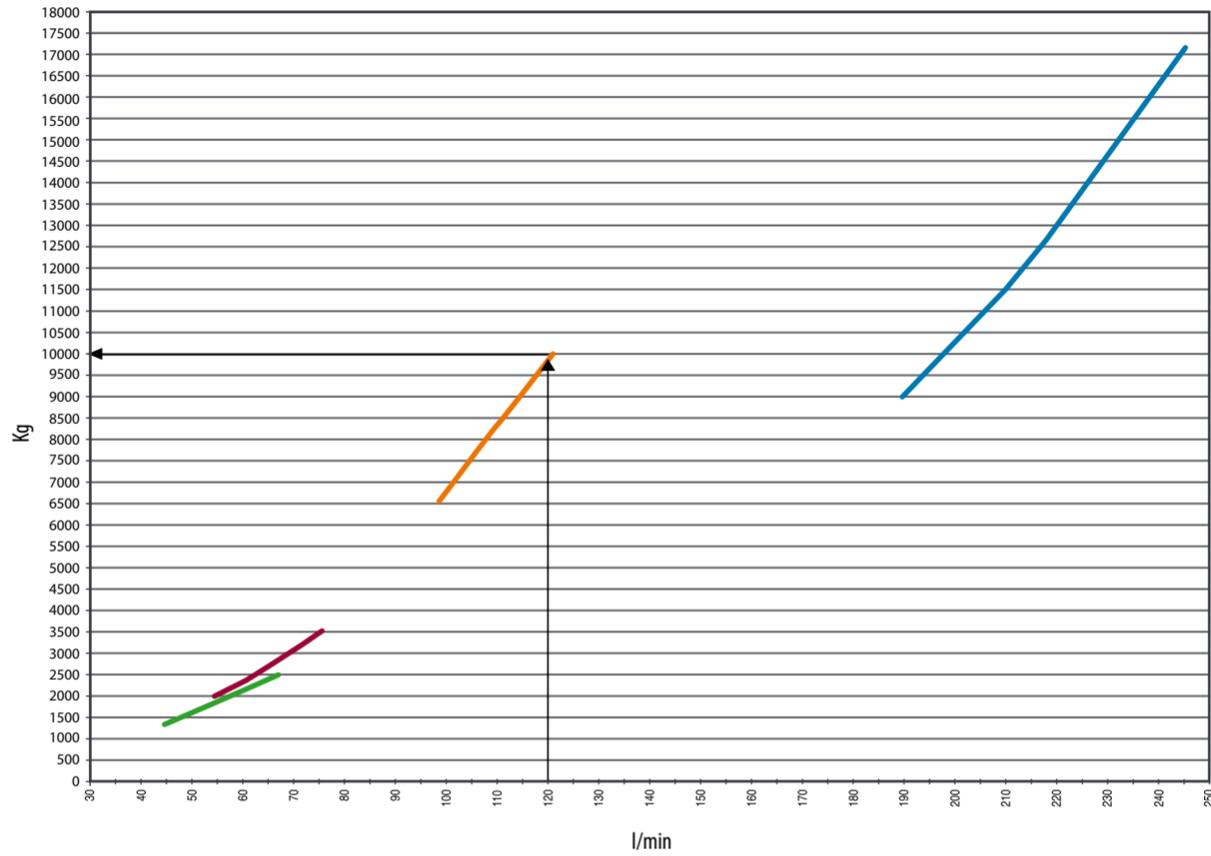

Example on an IHC/IHC R 150: a flow rate of 120 l/min corresponds to a centrifugal force of 69 kN.

— IHC/IHC R 50    — IHC/IHC R 70/75    — IHC/IHC R 150    — IHC/IHC R 250

# Accessories

## Backfill blade

A useful optional, mounted on the compactor, for smoothing and levelling the earth to be compacted, without needing to switch from compactor to bucket.



## The full range of other Indeco products

Products		Weight		Products		Weight		Products		Weight	
IFP	8 X	750	Kg	IHC	50	200	Kg	ISS***	10/20	2400	Kg
IFP	13 X	1300	Kg	IHC	70	445	Kg	ISS***	20/30	3650	Kg
IFP	19 X	1800	Kg	IHC	75	485	Kg	ISS***	25/40	4800	Kg
IFP	28 X	2800	Kg	IHC	150	970	Kg	ISS***	30/50	6100	Kg
IFP	35 X	3450	Kg	IHC	250	1280	Kg	ISS***	35/60	7600	Kg
IFP	45 X	4550	Kg	IHC R	50	425	Kg	ISS***	45/90	10400	Kg
IRP	5 X	570	Kg	IHC R	70	630	Kg	IMH	3	295	Kg
IRP	11 X	1150	Kg	IHC R	75	670	Kg	IMH	5	535	Kg
IRP	18 X	1700	Kg	IHC R	150	1185	Kg	IMH	6	555	Kg
IRP	23 X	2300	Kg	IHC R	250	1520	Kg	IMH	8	595	Kg
IRP	29 X	2950	Kg	IMG S**	400	380	Kg	IMH	10	735	Kg
IRP	36 X	3600	Kg	IMG S**	600	570	Kg	IMH	14	1045	Kg
IRP	45 X	4500	Kg	IMG S**	1200	1140	Kg	IMH	20	1495	Kg
IMP*	15	1500	Kg	IMG S**	1700	1610	Kg	IMH	28	1540	Kg
IMP*	20	2080	Kg	IMG S**	2300	2180	Kg	IMH	4.2 SS	1400	Kg
IMP*	25	2400	Kg	IMG S**	2800	2650	Kg	IMH	SG16	840	Kg
IMP*	35	3500	Kg	ISS***	5/7	570	Kg	IMH	SG20	840	Kg
IMP*	45	4500	Kg	ISS***	8/13	1250	Kg				

\*Crusher configuration - \*\*Sorter configuration - \*\*\*Third-member configuration

Indeco ind S.p.a.  
 viale Lindemann, 10 z.i. - 70132 Bari - Italy  
 tel. +39 080 531 33 70 - fax +39 080 537 79 76  
 info@indec0.it - www.indec0.it/en

